

FACILITY REQUIREMENTS

Mercury Base

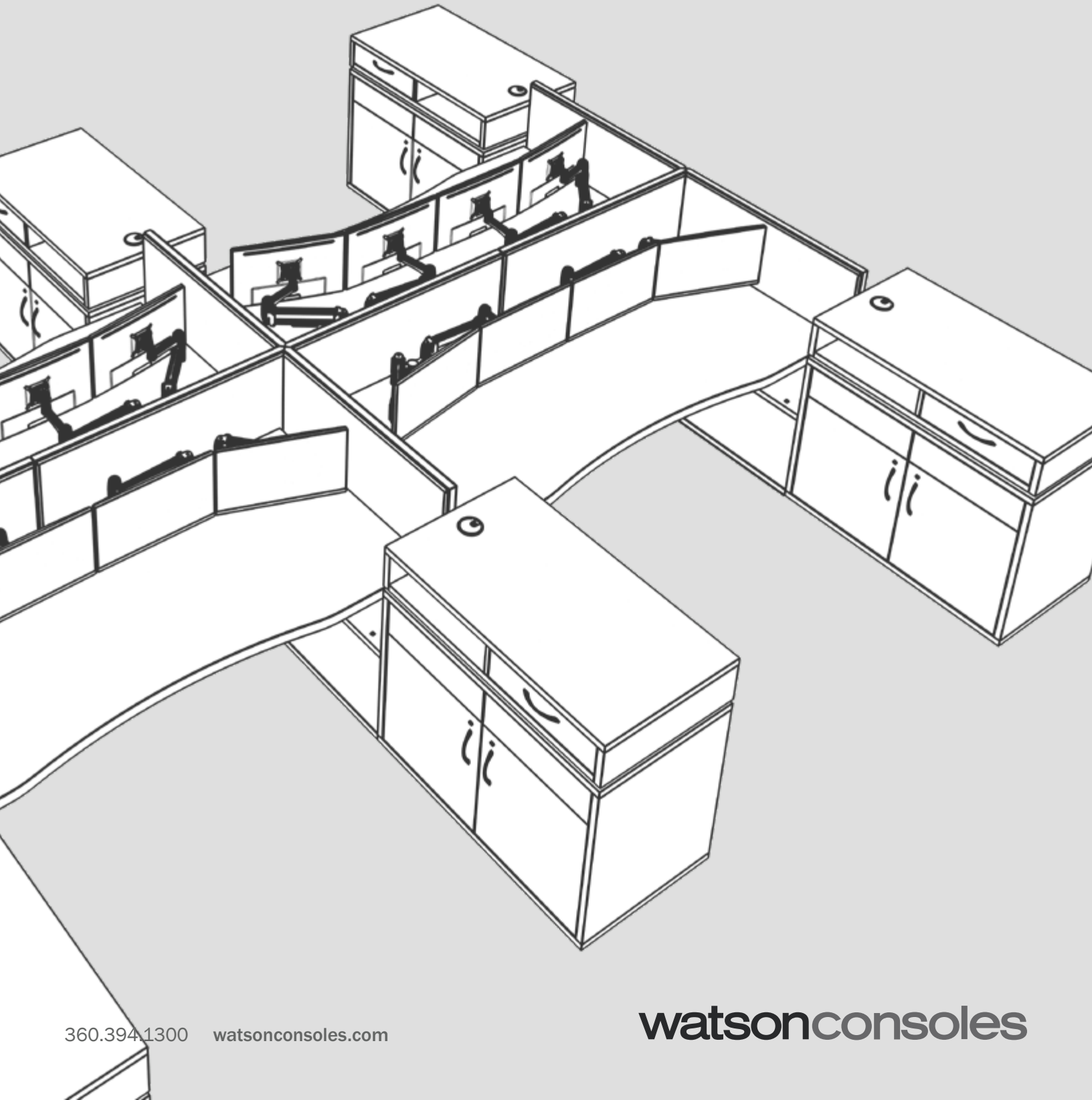

FACILITY REQUIREMENTS

Mercury Standard

CONSOLE POWER REQUIREMENTS	3
USER POWER RECOMMENDATION	4
TECHNOLOGY LOCATION TYPICAL	5
HUB CUTOUT LOCATIONS	6
CONNECTION TO BUILDING POWER	7

CONSOLE POWER REQUIREMENTS

Building Power Connection

Watson Consoles are connected either to NEMA 20R outlets located beneath the raised floor, on the wall, or by running conduit into the console and mounting junction boxes inside the console Hubs. There are dedicated cut-out locations in each console Hub and available mounting locations for junction boxes.

Technology Storage Unit Power Requirements

The Technology Storage unit includes integrated cooling fans which will add to the Total Console Power draw. The number of fans vary by storage type and quantity and will be determined by the final furniture configuration. Each fan adds an additional 80mA, with total power draw of 360mA for the largest furnishing. Typical layout allows power connection to a Power Distribution Unit (PDU) found in the adjacent Hub unit.

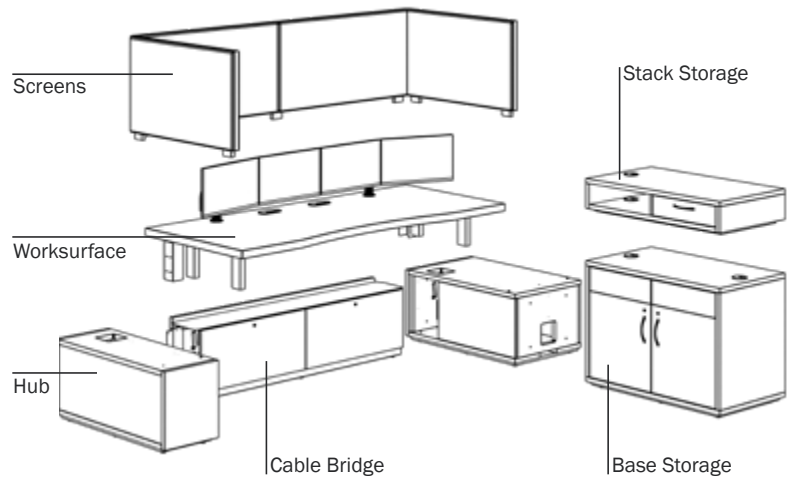

USER POWER RECOMMENDATION

Building Power Connection

Each console requires a minimum of two dedicated 15A circuits. One for Watson Console functions and a minimum of one for connection of the Power Distribution Units (PDUs). Two PDUs per console are provided. The number of circuits will vary based on end user requirements.



Power Distribution Unit —

Output

- 50/60 Hz compatibility
- Nominal output voltage 100-122V nominal, single phase
- 20A overload protection
- (10) NEMA 5-15R

Special Features

- TVSS grounding back panel nut and bolt grounding lug

Input

- PDU input voltage 120V AC
- 15 amp maximum input NEMA 5-15P
- 15 ft. input cord
- 120 VAC compatibility



Circuits

Minimum of 6 facility power outlets required (depends on number of circuits specified):

Watson Console Power Requirements:

- 1 Outlet: In-dash Power (if optioned/ordered)

Mission Critical Equipment Power Requirements:

- 2 Outlets: Hub PDUs (12 outlets each)
- 2 Outlets: In-Dash Monitor power strips
 - *These cannot be plugged into the PDUs as this will not meet code (considered a daisy chain)*

Both hub PDUs can be connected to a single circuit if the customer chooses. The number of circuits at the console is at the discretion of the customer.

5-20R DUPLEX / 20A/125V SINGLE PHASE

Circuit 1: Non-UPS Watson Console Power (If In-dash Power is ordered)

Circuit 2: UPS Mission Critical Equipment Power

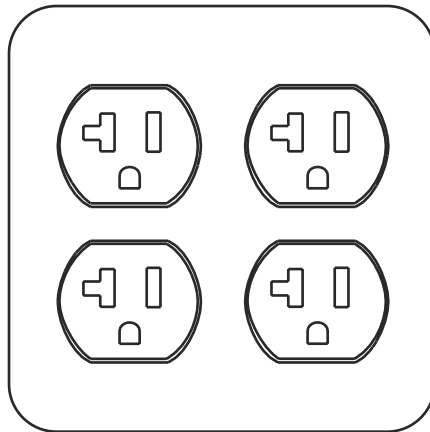
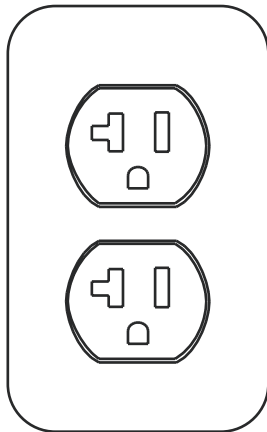

*This diagram represents the minimum requirements.

TECHNOLOGY LOCATION TYPICAL

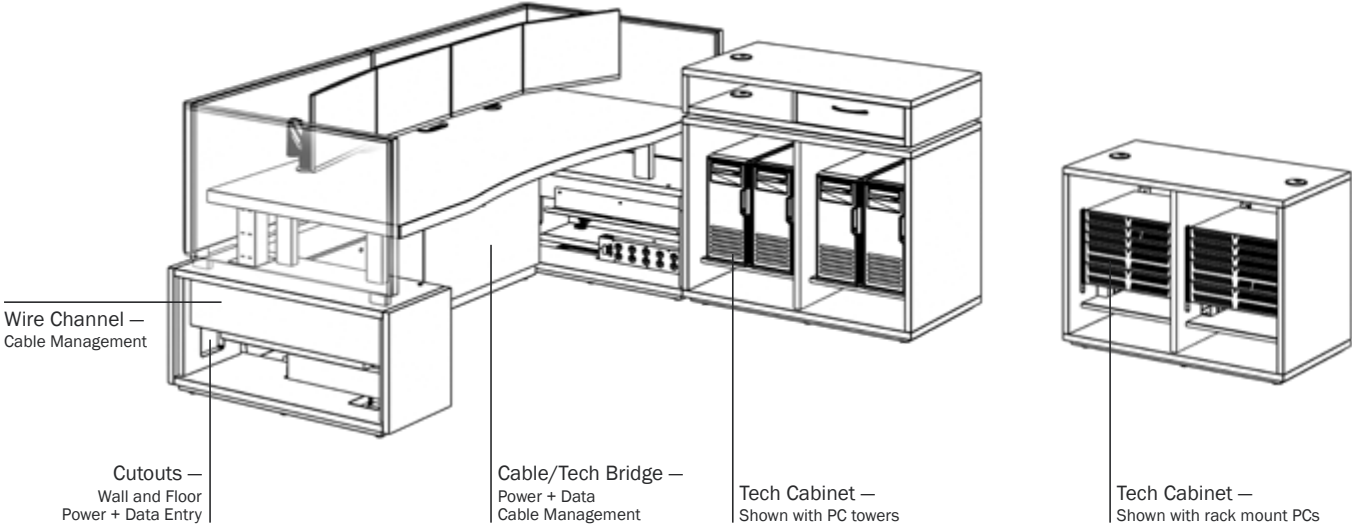

Back of Console

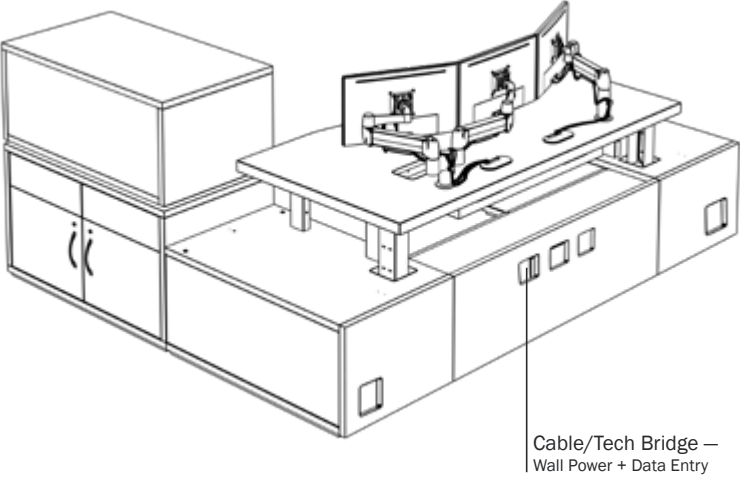

HUB CUTOUT LOCATIONS

Facility connection is dependent on specification. Mercury consoles are designed to accommodate facility power from wall and/or floor outlets. Facility power must only be routed through the hub cutouts shown.

15D x 39W Hub

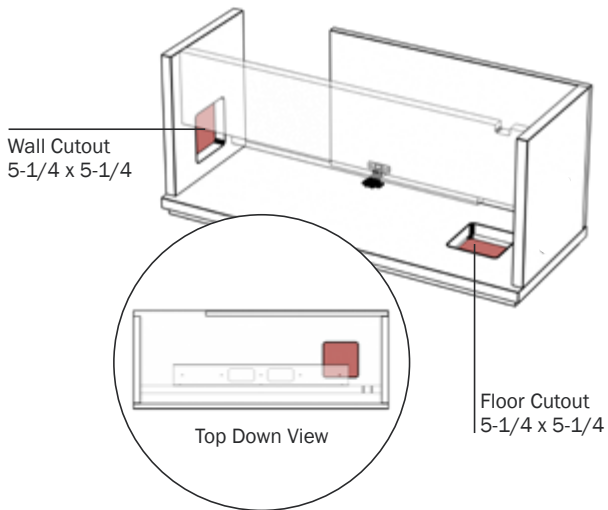

24D x 39W Hub

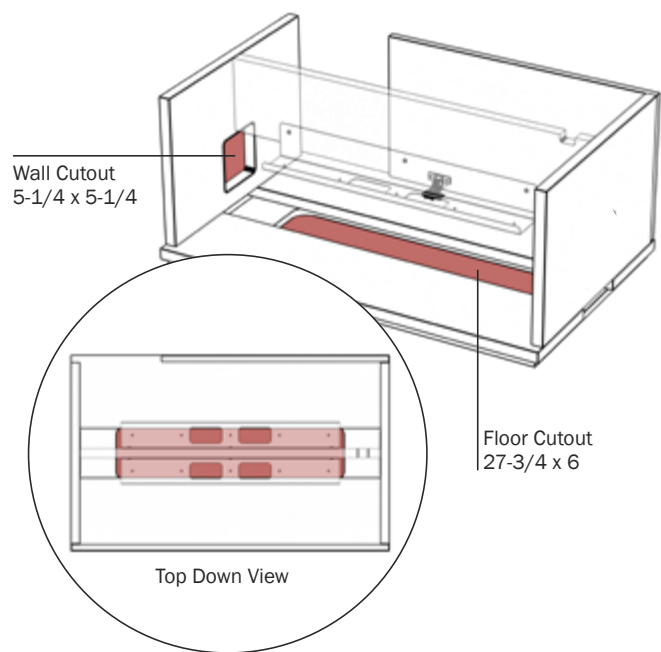

CONNECTION TO BUILDING POWER

Integrate Mercury and Facility Power

The illustrations below show examples of Mercury integrated with facility provided power and accessories. Power can also be fed from the ceiling via power poles or from the wall via the Tech/Cable Bridge (not pictured).

Option 1

Run flexible conduit from raised floor or wall into the console and terminate in a quad-receptacle junction box. Mounting locations for junction boxes are provided in the console (shown below).

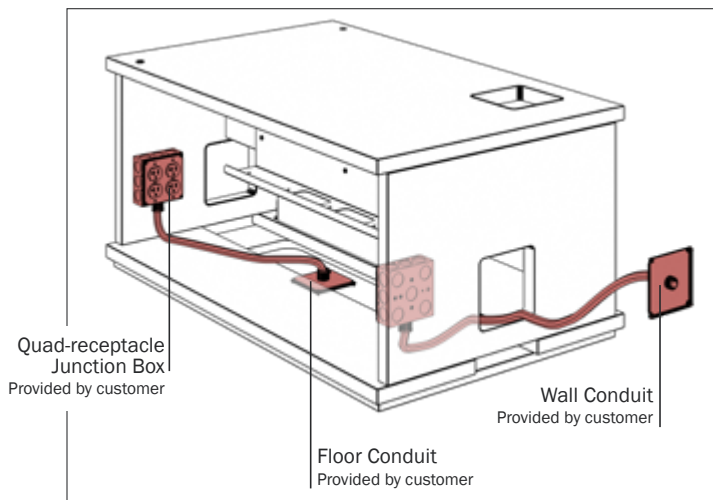

Option 2

Connect the main power cord directly to 15A wall or floor outlets. If possible, position facility outlets to align with console power access points. If 15A outlets are not available, contact Watson Consoles.

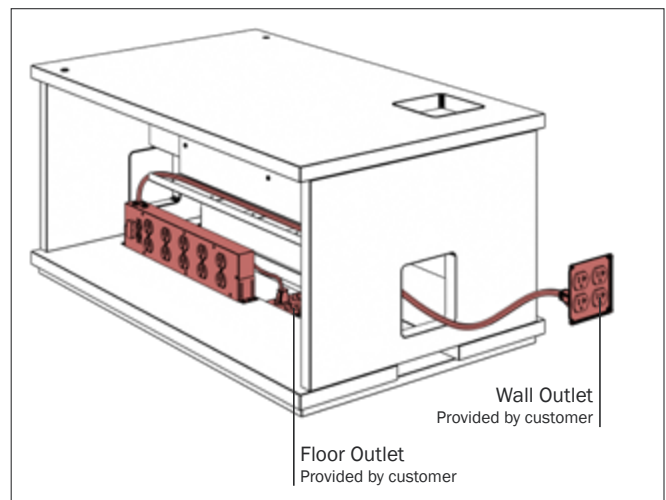

PDUs

PDUs are connected to mission critical building power. Ground lug is provided for connection into building grounding system. Handed hubs (15"W and 24"W) are specified with a single PDU. Center hubs (24"W) include 2 PDU's.

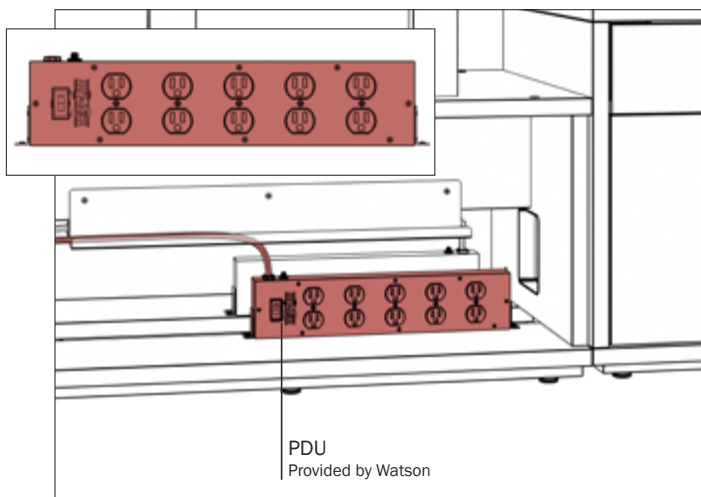

Network Switches

Network switches (not included) can be installed two ways:

A. Mount junction boxes to inside of inside of hub, cable bridge or technology cabinet (pictured).

